

REVISIONS			
REV.	DESCRIPTION	DATE	APPROVED
01	Standard filterboxes introduced. Filterboxes F7 redesigned	2016-03-09	EL

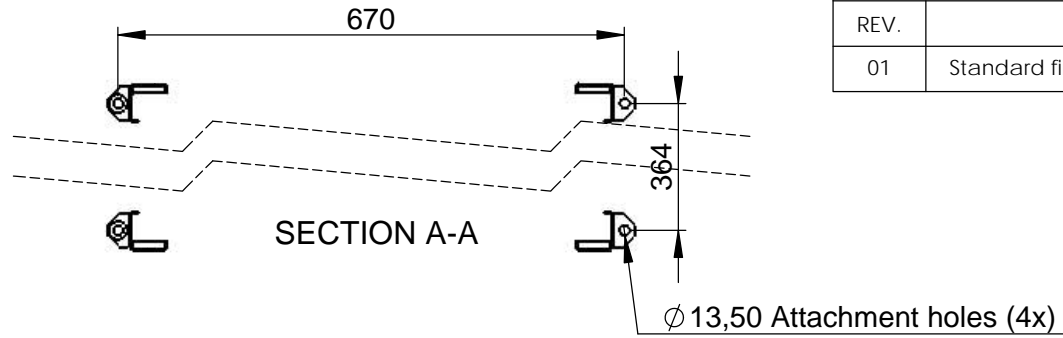

Removable top cover
 Elcetrical cabinet access
 Service space above unit = 500 mm

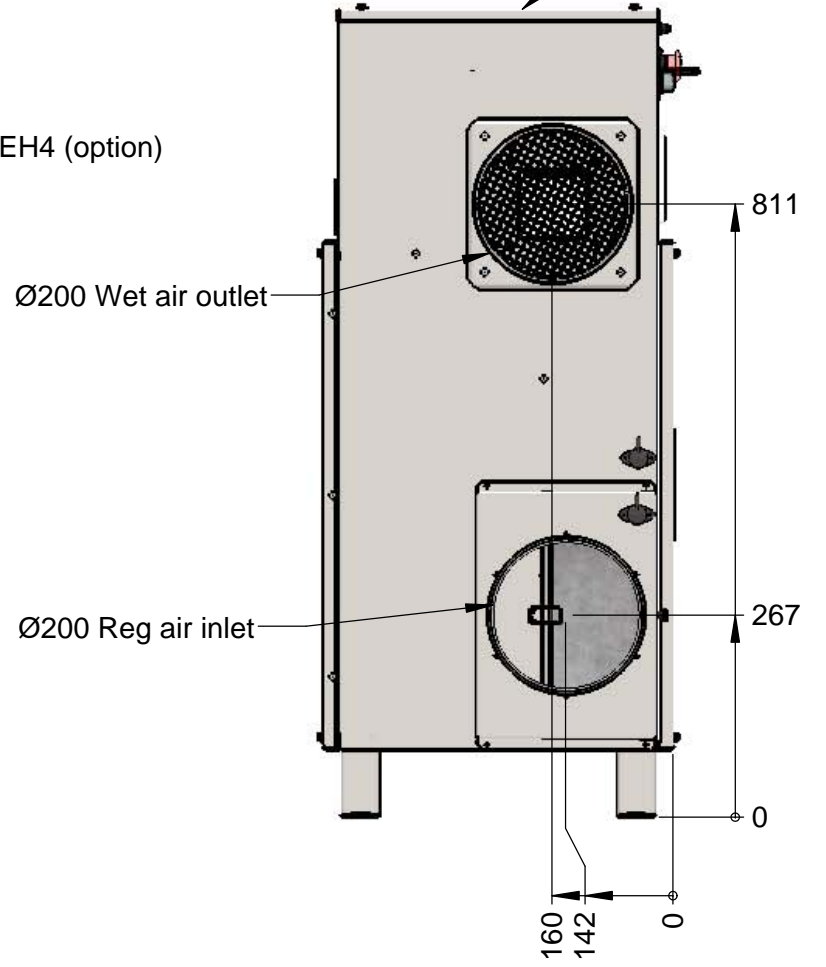
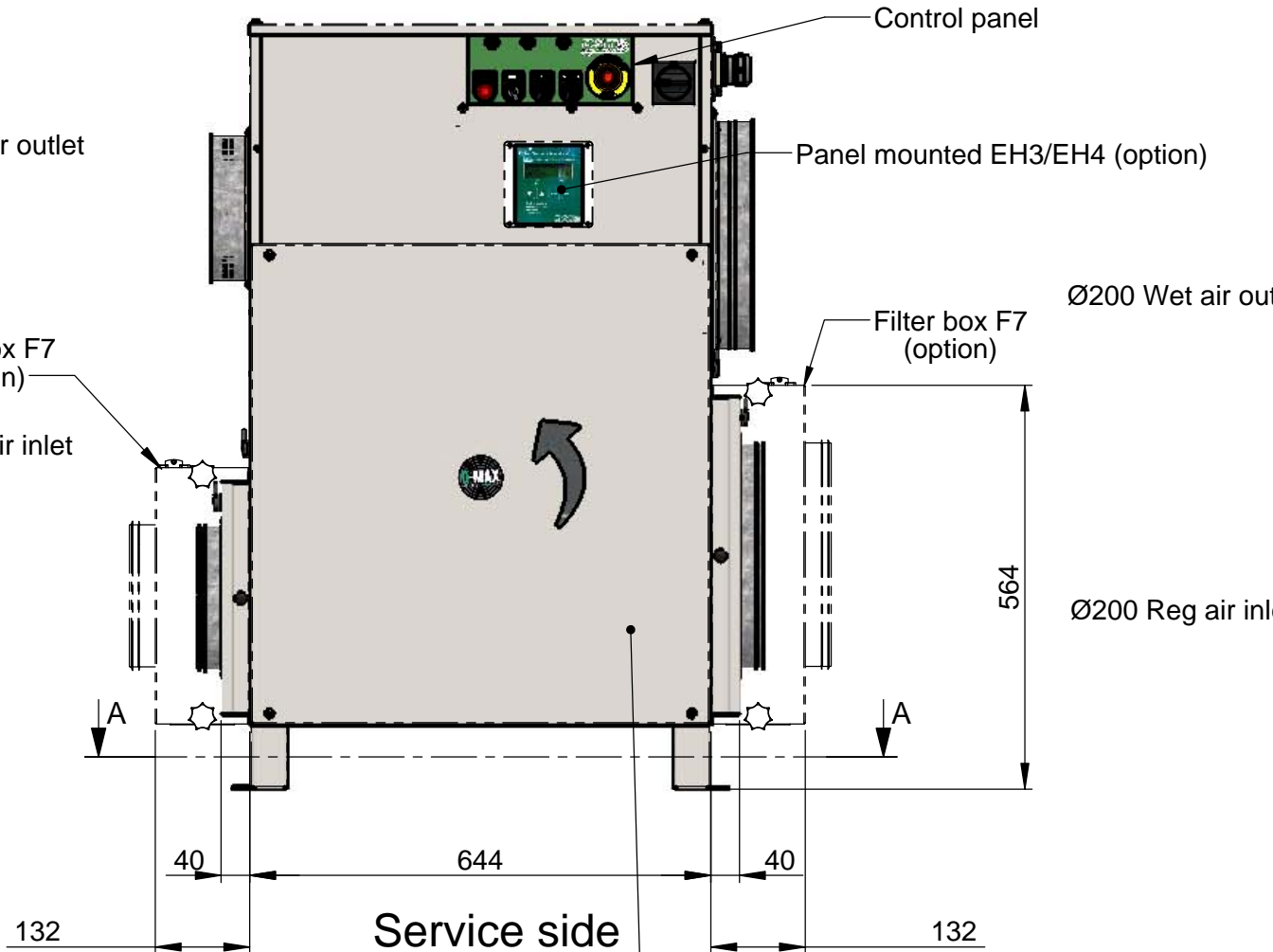
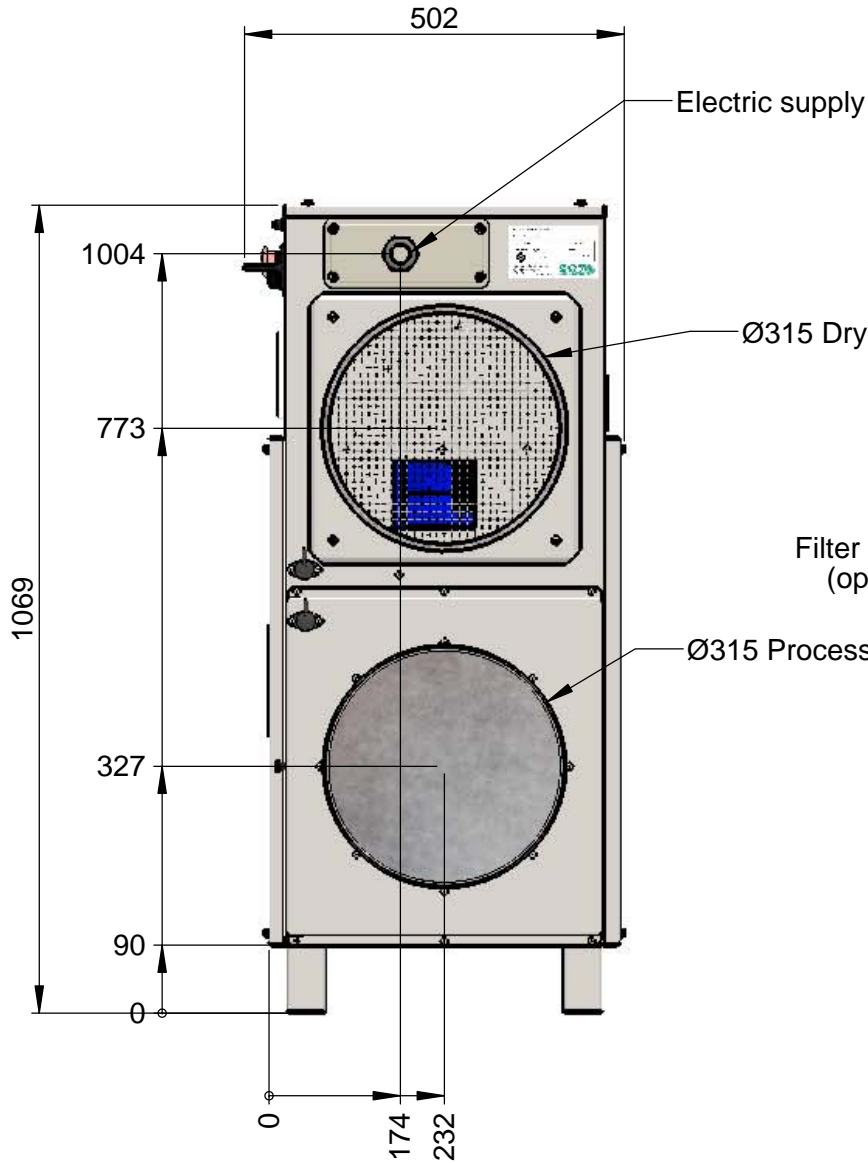

Packaging dimensions:
 WxDxH = 850x600x1200
 Weight ~70 kg

This document and its contents are the exclusive property of DST Seibu Giken and must not be copied, reproduced, transmitted or communicated to any other party or used for purposes not expressly permitted by us.

	Designed by Erik L	Date 2013-10-31	Title/Description Dimensionsritning Dimension drawing
	Drawn by Erik L	Date 2014-03-10	
	Approved by -	Date -	RL-60 R/LR
	Material -	Thickness t=	
Seibu Giken DST AB +46 8 445 77 20 www.dst-sg.com	Status Construction	Tolerance ISO 2768-1m	Drawing no DST05145
	Scale 1:10	Format A3	
	Rev Part 01	Weight (Kg) 73.869	Rev 01+